

KUSAM-MECO

**DIGITAL AC
CLAMP METER
MODEL - KM 2700 / KM 2790**

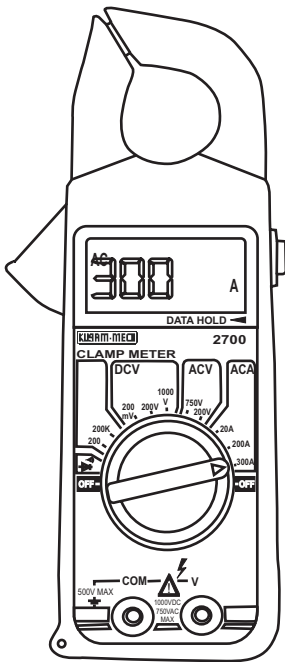

OPERATION MANUAL

KUSAM-MECO

Table of Contents

Title	Page
Overview.....	1
Unpacking Inspection.....	2
Rules For Safe Operation.....	3
International Electrical Symbols.....	5
The multimeter Structure.....	6
Functional Buttons.....	7
Display Symbols.....	8
Measurement Operation.....	10
A. DC Voltage Measurement.....	10
B. AC Voltage Measurement.....	11
C. AC Current Measurement.....	13
D. Measuring Resistance.....	14
E. Measuring Diodes & Continuity.....	16
F. Measuring Frequency.....	18
General Specifications	20
Electrical Specifications	21
A. AC Current.....	21
B. AC Voltage.....	21
C. DC Voltage.....	21
D. Resistance.....	22
E. Diodes and Continuity Test.....	22
F. Frequency.....	22
Maintenance	23
A. Replacing the Battery.....	23
Test Certificate	24
Warranty	25

Overview

Warning

To avoid electric shock or personal injury, read the “Safety Information” and “Rules for Safe Operation” carefully before using the Meter.

Digital Clampmeter Model - 2700/2790 (hereafter referred to as “the Meter”) is a 3½ digits Clampmeter with steady operations, and highly reliable hand-held measuring instrument having different measurement positions. The Clampmeter not only can measure AC/DC Voltage, AC Current, Resistance, Diodes and Continuity, Frequency (in model 2790) but also has Data Hold, Full Icon Display.

Terms in this manual

 **Warning** : identifies conditions and actions that could result in serious injury or even death to the user.

 **Caution** : identifies conditions and Actions that could cause damage or malfunction in the instrument.

Unpacking Inspection

Open the package case and take out the Clampmeter. Check the following items carefully to see any missing or damaged part :

Item	Description	Qty.
1	English Operating Manual	1 piece
2	Test Lead	1 pair

In the event you find any Part missing or damaged, please contact your dealer immediately.

Rules For Safe Operation (1)**Warning**

To avoid possible electric shock or personal injury, and to avoid possible damage to the Meter or to the equipment under test, adhere to the following rules :

- Before using the Meter inspect the case. Do not use the Meter if it is damaged or the case (or part of the case) is removed. Look for cracks or missing plastic. Pay attention to the insulation around the connectors and Clamps.
- Inspect the test leads for damaged insulation or exposed metal. Check the test leads for Continuity. Replace damaged test leads with identical electrical Specifications before using the Meter.
- Do not apply more than the rated voltage, as marked on the Meter, between the terminals or between any terminal and grounding.
- The rotary switch should be placed in the right position and no any changeover of range shall be made while measurement is conducted to prevent damage of the Meter.
- When measurement is taken at an effective voltage over 60V in DC or 30V rms in AC, special care should be taken for there is danger of electric shock.
- Use the proper terminals, function, and range for your measurements.
- Do not use or store the Meter in an environment of high temperature, humidity, explosive, inflammable and strong magnetic field. The performance of the Meter may deteriorate after the meter is dampened.
- When using the test leads, keep your fingers behind the finger guards.

Rules For Safe Operation (2)

- Disconnect circuit power and discharge all high-voltage capacitors before testing resistance, continuity, diodes, or current.
- Replace the battery as soon as the battery indicator  appears. With a low battery, the Meter might produce false readings that can lead to electric shock and personal injury.
- Turn the Meter power off when it is not in use and take out the battery when not using for a long time.
- Constantly check the battery as it may leak when it has not been used for some time, replace the battery as soon as leaking appears. A leaking battery will damage the Meter.

International Electrical Symbols

	AC (Alternating Current).
---	DC (Direct Current).
—	Both DC & AC.
⏏	Grounding.
□	Double Insulated.
⊕	Deficiency of Built-In Battery.
•)))	Continuity Test.
→	Diode.
—	Fuse.
⚠	Warning ! Refer to the Operating Manual.
⚡	Caution ! Risk of Electric Shock.

The Clampmeter Structure (see figure 1)

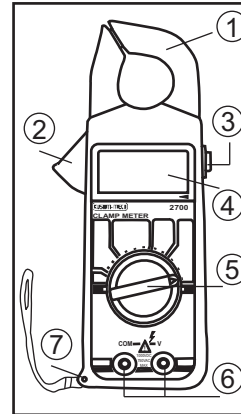

(Figure 1)

- 1) **TRANSFORMER JAWS :**
Pick up the AC current flowing through the conductor.
- 2) **TRIGGER :**
Press the lever to open the transformer jaws
When the lever is released, the jaws will close again.
- 3) **DATA HOLD SWITCH :**
A push switch (push ON/OFF) Data-Hold switch will freeze reading when pressed.
- 4) **LCD DISPLAY :**
A 3½ digit display (maximum reading 1999) indicates measured values, and features symbols indicating function, Data - Hold, Low Battery, Continuity, Diode.
- 5) **FUNCTION SELECTOR :**
To Select ACV, ACA, DCV, RESISTANCE, FREQUENCY (in model 2790).

- 6) **INPUT JACKS (V and COM) :**
 Test leads are inserted into these jacks for Voltage, Resistance, Frequency (in Model - 2790) measurements and Continuity & Diode Checks.
- 7) **DROP- PROOF WRIST STRAP :**
 Prevents the instrument from slipping off the hand while in use.

Functional Buttons



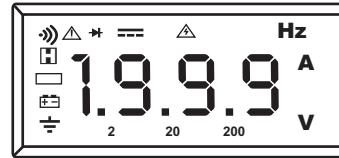

Below table indicates the functional button operations

Buttons	Operation Performed
POWER (Yellow Switch)	Turn the Meter on and off. <ul style="list-style-type: none"> ● Rotate the SWITCH to turn on the Meter. ● Rotate the SWITCH to turn off the Meter.
DATA HOLD (Yellow Button)	<ul style="list-style-type: none"> ● Press DATA HOLD once to enter hold mode. ● Press DATA HOLD again to exit hold mode. ● In Hold mode,  is displayed and the present value is shown.

Display Symbols (see figure 2)



(Figure 2)

No.	Symbol	Meaning
1		Dangerous Voltages.
2		The battery is low. ⚠ Warning : To avoid false readings, which could lead to possible electric shock or personal injury, replace the battery as soon as the battery indicator appears.
3		Indicator for AC voltage or current, The displayed value is the mean value.
4	—	Indicates negative reading.
5		Test of diode.
6		Data Hold is active.
7		The continuity buzzer is on.
8	A	A : Amperes (amps). The unit of current.
9	V	V : Volts. The unit of voltage.
10	Hz	Hz : frequency. The unit of frequency (in Model 2790)

Display Symbols (see figure 2)

NO.	Symbol	Meaning
11	, k ,	: Ohm. The unit of resistance. K : kilohm. 1×10^3 or 1000 ohms.

Measurement Operation

- Make sure the Low Battery display  is not on, otherwise false readings may be provided.
- Pay extra attention to the Δ symbol which is located besides the input terminals of the Meter before carrying out measurement.

A. DC voltage measurement (see figure 3)

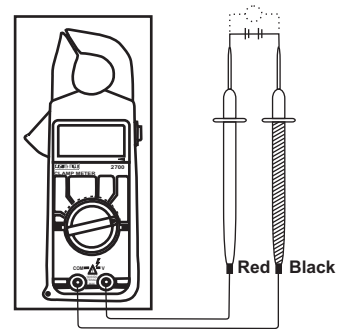



(Figure 3)

Δ **Warning**

To avoid harm to you or damages to the Meter from electric shock, please do not attempt to measure voltages higher than 1000V DC or 750V AC rms although readings may be obtained.

The DC Voltage ranges are : 2V, 200V and 1000V. To measure DC voltage, connect the Meter as follows :

- 1) Insert the red test lead into the V  input terminal and the black test lead into the COM input terminal
- 2) Set the rotary switch to an appropriate measurement position in V  range.
- 3) Connect the test leads across with the object being measured.

The measured value shows on the display.

⚠ Caution :

- If the value of voltage to be measured is unknown, use the maximum measurement position (1000V) and reduce the range step by step until a satisfactory reading is obtained.
- The LCD displays "1" indicating the existing selected range is overloaded, it is required to select a higher range in order to obtain a correct reading.
- In each range, the Meter has an input impedance of approx. $10M$. This loading effect can cause measurement errors in high impedance circuits.
If the circuit impedance is less than or equal to $10k$, the error is negligible (0.1% or less).
- When DC voltage measurement has been completed, disconnect the connection between the testing leads and the circuit under test.

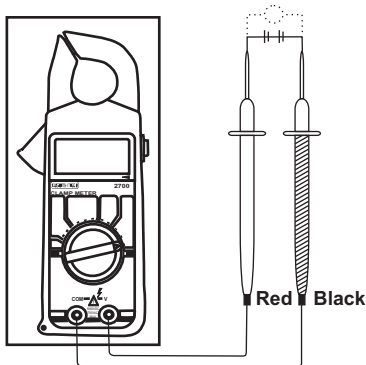
B. AC Voltage Measurement (see figure 4)**(figure 4)****⚠ Warning :**

To avoid harm to you or damages to the Meter from electric shock, please do not attempt to measure voltages higher than 1000V or 750V rms although readings may be obtained.

The AC voltage measurement has 2 measurement positions on the rotary switch : 200V and 750V

To measure AC Voltage, connect the Meter as follows :

- 1) Insert the red test lead into the V \rightarrow Terminal and the black test lead into the **COM** terminal.
- 2) Set the rotary switch to an appropriate measurement position in V \sim range.
- 3) Connect the test leads across with the object being measured.

The measured value shown on the display, is effective value of sine wave (mean value response).

⚠ Caution :

- If the value of voltage to be measured is unknown, use the maximum measurement position (750V) and reduce the range step by step until a satisfactory reading is obtained.
- The LCD displays " 1 " indicating the existing selected range is overloaded, it is required to select a higher range in order to obtain a correct reading.
- When AC voltage measurement has been completed, disconnect the connection between the testing leads and the circuit under test.

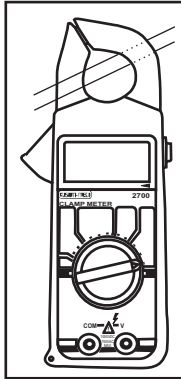
C. AC Current Measurement (see figure 5)

(figure 5)

Warning

Never attempt an in-circuit current measurement where the voltage between terminals and ground is greater than 60V.

Use proper function, and range for the current measurement.

The AC Current measurement has 3 measurement positions on the rotary Switch : 20A, 200A, 300A, 600A* (in Model - 2790)

To measure AC Current :

- 1) Open the jaw and place the conductor in the center of the jaw for accurate measurement.
- 2) Set the rotary switch to an appropriate measurement position in AC current range. The measured value is shown on the display.

Caution :

- 1) Place the switch in the 300A range position if the measured current is unknown. Rotate the switch to lower positions to get more accurate readings.

- 2) The LCD displays “ 1 ” indicating the existing selected range is overloaded, it is required to select a higher range in order to obtain a correct reading.
- 3) When AC Current measurement has been completed, Open the jaw to remove the conductor & then Switch off the meter.

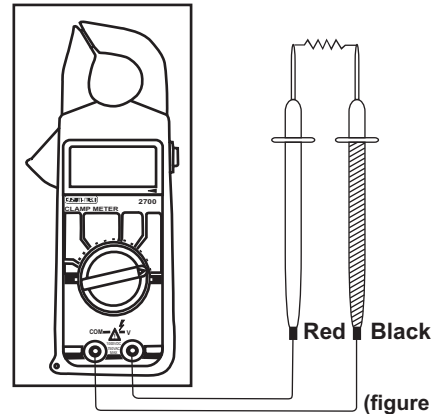
D. Resistance Measurement (see figure 6)

(figure 6)

Warning

To avoid damages to the Meter or to the devices under test, disconnect circuit power and discharge all the high-voltage capacitors before measuring resistance.

The resistance range has 2 measurement positions on the rotary switch : 200 , 200k .

To measure resistance, connect the meter as follows

- 1) Insert the red test lead into the V \rightarrow terminal and the black test lead into the **COM** terminal.
- 2) Set the rotary switch to an appropriate measurement position in range.
- 3) Connect the test leads across with the object being measured.
The measured value shows on the display.

Note :

- The test leads can add 0.1 to 0.3 of error to the Resistance measurement. To obtain precision readings in low-resistance, that is the range of 200 , short-circuit the input terminals beforehand and record the reading obtained (call this reading as X). (X) is the additional resistance from the test lead.
- Then use the equation :
Measured resistance value (Y) - (X) = precision readings of resistance.
- When there is no input, for example in open circuit condition, the Meter displays " 1 ".
When resistance measurement has been completed, disconnect the connection between the testing leads and the circuit under test.



Caution:

- 1) Never connect high voltage to the input sockets with the switch in Resistance range.
- 2) Using Resistance measurement function in a live circuit will produce false results and may damage the instrument. In many cases the suspect component must be disconnected from the circuit to obtain an accurate reading.

E. Measuring Diodes & Continuity (See figure 7)



Warning

To avoid damage to the Meter or to the equipment under test, disconnect circuit power and discharge all high-voltage capacitors before measuring diodes and continuity.

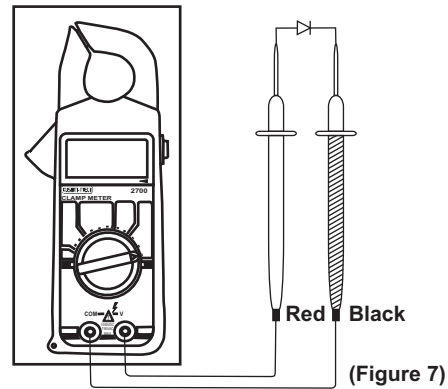

Testing Diodes

Use the diode test function to check diodes, The diode test sends a current through the semiconductor junction, and then measures the voltage drop across the junction. A good silicon junction drops between 0.5V and 0.8V.

To test a diode out of a circuit, connect the Meter as follows :

- 1) Insert the red test lead into the V \rightarrow terminal and the black test lead into the COM terminal.
- 2) Set the rotary switch to \rightarrow \rightarrow position.

- 3) For forward voltage drop reading on any Semiconductor component, place the red test lead on the component's anode and place the black test lead on the component's cathode. The measured value shows on the display.



Caution :

- In a circuit, a good diode will produce a forward voltage drop reading of 0.5V to 0.8V; however; the reverse voltage drop reading can vary depending on the resistance of other pathways between the probe tips.
- Connect the test leads to the proper terminals as said above, to avoid error display. The LCD will display "1" indicating open-circuit for wrong connection. The unit of diode is Volt (V), displaying the positive connection voltage-drop value.
- When diode testing has been completed, disconnect the connection between the testing leads and the circuit under test.

Testing for Continuity

To test for continuity, connect the Meter as below :

1. Insert the red test lead into V \rightarrow terminal and the black test lead into the **COM** terminal.
2. Set the rotary switch to \rightarrow \rightarrow \rightarrow position.
3. Connect the test leads across with the object being measured.

The buzzer sounds if the resistance of the circuit under test is less than 30 .

The LCD displays the resistance value of the circuit under test.



Caution :

- The LCD displays "1" indicating the circuit being tested is open.

- When continuity testing has been completed, disconnect the connection between the testing leads and the circuit under test.

F: Frequency Measurement (in model 2790)
(see figure 8)

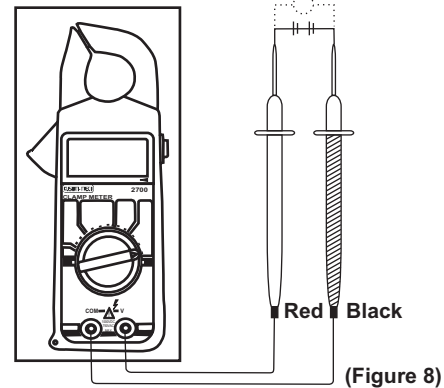

Warning :

To avoid harm to you or damages to the Meter, do not attempt to measure voltages higher than 60V in DC or 30V rms in AC although reading may be obtained.

When the frequency signal to be tested is higher than 30V rms, the Meter cannot guarantee accuracy of the measurement.

The frequency measurement ranges is 20kHz.

To measure frequency, connect the Meter as follows :

- 1) Insert the red test lead into the V terminal and the black test lead into the **COM** Terminal.

- 2) Set the rotary switch in the Hz range.
- 3) Connect the test leads across with the object being measured. The measured value shows on the display.

⚠ Caution :

- When Hz measurement has been completed, disconnect the connection between the testing leads and the circuit under test.

FEATURES :

- HIGH - ACCURACY, DIGITAL READING.
- LARGE LCD FOR EASY READING.
- INSTANT CONTINUITY BUZZER.
- OVERLOAD PROTECTION ON ALL RANGES.
- RECESSED SAFETY DESIGNED INPUT JACKS.
- " DATA - HOLD " SWITCH FREEZES READING.

GENERAL SPECIFICATIONS :

Display : 3½ digit LCD. maximum reading 1999 with automatic sign and Function annunciators.

Overrange indication : MSB (highest) digit OL (1) or (-1) is displayed.

Low battery : "  " is displayed when the battery voltage drops below the operating voltage.

Measurement rate : 3 measurements per second, nominal.

Operating temperature : 0°C to + 50°C, 0-70% RH.

Storage temperature : -20°C to 60°C, 0-80% RH with battery removed.

Accuracy : Accuracy specifications at 23 ± 5°C less than 75% RH.

Power : Single standard 9 - Volt Battery

Dimension : 19.2cm long, 8.2cm wide, 3.3 cm high.

Weight : Approx (250 grams) including battery.

Accessories : Test leads (pair), Battery, Operators Manual, Carrying Case.

ELECTRICAL SPECIFICATION

- Accuracies are \pm (% reading + number of digits).
at $23 \pm 5^\circ\text{C}$ less than 75% R.H.

AC CURRENT (50~60 Hz)

Range	Resolution	Accuracy
20 A	0.01 A	\pm (3% rdg + 4 dgts.)
200 A	0.1 A	\pm (2% rdg + 4 dgts.)
300 A	1 A	
600 A*	1 A	\pm (1.5% rdg + 4 dgts.)

AC VOLTAGE (50~500 Hz)

Range	Resolution	Accuracy
200 V	0.1 V	\pm (1.2% rdg + 4 dgts.)
750 V	1 V	\pm (1.5% rdg + 4 dgts.)

INPUT IMPEDANCE : 10 M

OL - PROTECTION : 1200 VDC/800 VAC ON ALL RANGES.

DC VOLTAGE

Range	Resolution	Accuracy
2 V	1 mV	\pm (0.5% rdg + 1 dgt)
200 V	0.1 V	
1000 V	1 V	

INPUT IMPEDANCE : 10M

OL - PROTECTION : 500VDC/350VAC ON 200mV RANGE
1200VDC/800VAC ON OTHER RANGE.

* 600A range in Model - 2790

RESISTANCE

Range	Resolution	Accuracy
200	0.1	\pm (1% rdg + 1 dgt)
200 K	100	

TEST VOLTAGE : 200 RANGE 3.2V MAX.

200K RANGE 0.3V MAX.

OL - PROTECTION : 500VDC/350VAC ON ALL RANGE

DIODE TEST

TEST CURRENT	1.0 \pm 0.6mA
TEST VOLTAGE	3.2V MAX.

OL - PROTECTION : 500VDC/350VAC.

CONTINUITY BEEPER

THRESHOLD	< 30
RESPONSE TIME	< 100mS

OL - PROTECTION : 500VDC/350VAC.

FREQUENCY (Autoranging)

Frequency function in Model - 2790

Range	Accuracy
2 KHz	\pm (0.5% rdg + 3 dgts)
20 KHz	

SENSITIVITY : 80Vrms min.

OL - PROTECTION : 500VDC or AC rms
(50Hz ~ 500Hz).

Maintenance**△Warning**

To avoid false reading, replace the battery as soon as the battery indicator  appears.

To replace battery :

- Disconnect the connection between the testing leads and the circuit under test, and remove the testing leads away from the input terminals of the Meter.
- Turn the Meter OFF.
- Remove the screws from the battery compartment, and separate the battery compartment from the case bottom.
- Remove the battery from the battery compartment.
- Replace the battery with a new Standard 9V Battery.
- Rejoin the battery compartment and the case bottom, and install the screw.

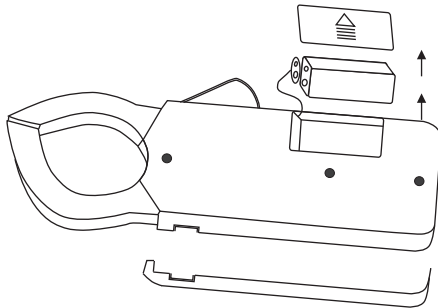

MUMBAI

TEST CERTIFICATE**DIGITAL AC CLAMPMETER**

This Test Certificate warrants that the product has been inspected and tested in accordance with the published specifications.

The instrument has been calibrated by using equipment which has already been calibrated to standards traceable to national standards.

MODEL NO. **2700**

SERIAL NO. _____

DATE: _____

ISO 9001
REGISTERED

KUSAM-MECO

WARRANTY

Each "KUSAM-MECO" product is warranted to be free from defects in material and workmanship under normal use & service. The warranty period is one year (12 months) and begins from the date of despatch of goods. In case any defect occurs in functioning of the instrument, under proper use, within the warranty period, the same will be rectified by us free of charges, provided the to and fro freight charges are borne by you.

This warranty extends only to the original buyer or end-user customer of a "KUSAM-MECO" authorized dealer.

This warranty does not apply for damaged IC's, fuses, burnt PCB's, disposable batteries, carrying case, test leads, or to any product which in "KUSAM-MECO's" opinion, has been misused, altered, neglected, contaminated or damaged by accident or abnormal conditions of operation or handling.

"KUSAM-MECO" authorized dealer shall extend this warranty on new and unused products to end-user customers only but have no authority to extend a greater or different warranty on behalf of "KUSAM-MECO".

"KUSAM-MECO's" warranty obligation is limited, at option, free of charge repair, or replacement of a defective product which is returned to a "KUSAM-MECO" authorized service center within the warranty period.

KUSAM-MECO

THIS WARRANTY IS BUYER'S SOLE AND EXCLUSIVE REMEDY AND IS IN LIEU OF ALL OTHER WARRANTIES, EXPRESS OR IMPLIED, INCLUDING BUT NOT LIMITED TO ANY IMPLIED WARRANTY OF MERCHANTABILITY OR FITNESS FOR A PARTICULAR PURPOSE. "KUSAM-MECO" SHALL NOT BE LIABLE FOR ANY SPECIAL, INDIRECT, INCIDENTAL OR CONSEQUENTIAL DAMAGES OR LOSSES, INCLUDING LOSS OF DATA, ARISING FROM ANY CAUSE WHATSOEVER.

All transactions are subject to Mumbai Jurisdiction.

KUSAM-MECO

G 17, Bharat Industrial Estate, T. J. Road,
Sewree (W), Mumbai - 400 015. INDIA.

Sales Direct : (022) 24156638

Tel. : (022) 24124540, 24181649.

Fax : (022) 24149659

Email : kusam_meco@vsnl.net

Website : kusam-meco.co.in, kusamelectrical.com